

# Haven Seavoyager



Type of vessel:	Flat Top Spud Leg Barge
Length o.a.:	33.96 m
Breadth o.a.:	11.0 m
Depth o.a. Hull:	2.8 m
Deck Area	373.56 m <sup>2</sup>
Max Spud Leg Length:	25 m
Spud Leg Diameter:	0.61 m
Gross Tonnage:	260 GT
Lightship Weight:	tbc Tonnes
Allowable Deck Load:	At Sea: tbc Tonnes, Sheltered Water: tbc Tonnes
Allowable Deck Point Load:	6.00 Tonnes/m <sup>2</sup>
Draft at Zero Load:	tbc m
Draft at Maximum Load:	tbc m
Certification:	Port of London Authority Licensed  Pending Classification by Bureau Veritas (I Pontoon Unrestricted Navigation International Loadline)
Optional Equipment:	Winches, Anchors, Fenders, Crane Mats, Hand Railing, Spud Legs



**RED7MARINE**  
MARINE CONSTRUCTION  
DIVING AND SUBSEA

RED7MARINE LTD  
SHORE FARM  
WRABNESS  
MANNINGTREE  
CO11 2TG

**Tel:** +44 (0)1255 886710  
**Fax:** +44 (0)1255 886658  
**Email:** enquiries@r7m.co.uk  
**Web:** www.red7marine.co.uk

# Haven Seavoyager

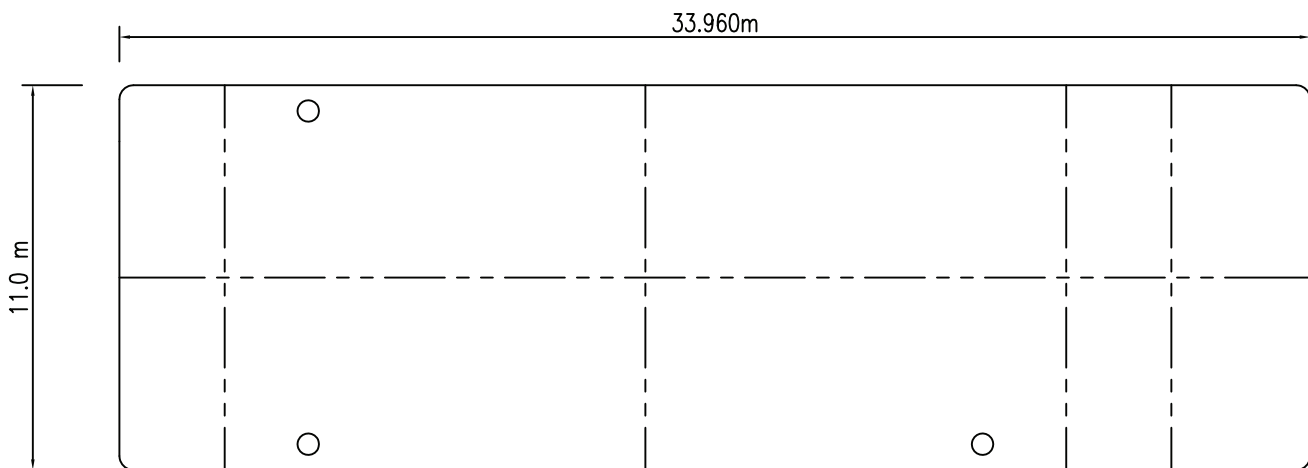

Plan View

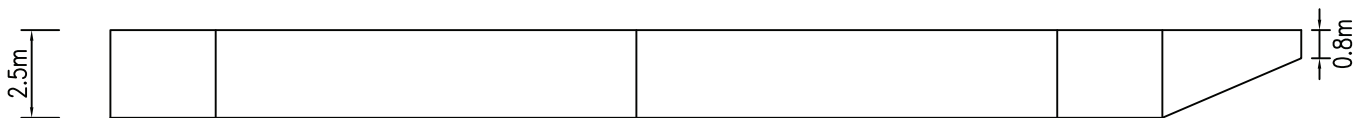

Side Elevation



**RED7MARINE**  
MARINE CONSTRUCTION  
DIVING AND SUBSEA

RED7MARINE LTD  
SHORE FARM  
WRABNESS  
MANNINGTREE  
CO11 2TG

**Tel:** +44 (0)1255 886710  
**Fax:** +44 (0)1255 886658  
**Email:** [enquiries@r7m.co.uk](mailto:enquiries@r7m.co.uk)  
**Web:** [www.red7marine.co.uk](http://www.red7marine.co.uk)